

Shuttering magnet

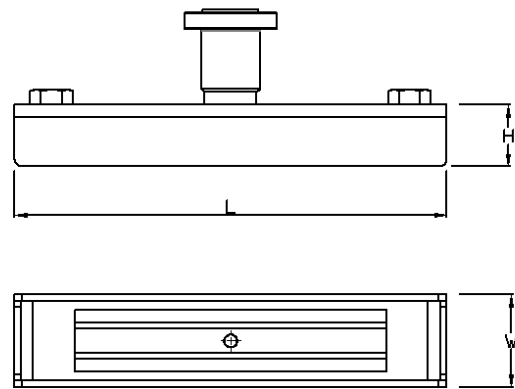

Item No.	L	W	H	Force			weight
	mm	mm	mm	Kg	N	Lbs	KG
SM-450	170	60	40	450	4410	991	2.7
SM-900	280	60	40	900	8820	1982	4.5
SM-1500	320	120	60	1500	14700	3304	8
SM-1800	320	120	60	1800	17640	3965	9
SM-2100	320	120	60	2100	20580	4625	10



*We test the holding force of magnetic assembly by attaching it on a 20mm thick steel sheet at room temperature and then pulling it slowly in vertical direction with the device that is sensitive enough to record the strength at the moment when magnetic assembly is separated from the steel sheet. This is to give you a reference where the actual holding force in real application could be different with the change of, for example, pulling direction, thickness of the surface etc.

Shuttering magnet with back plate

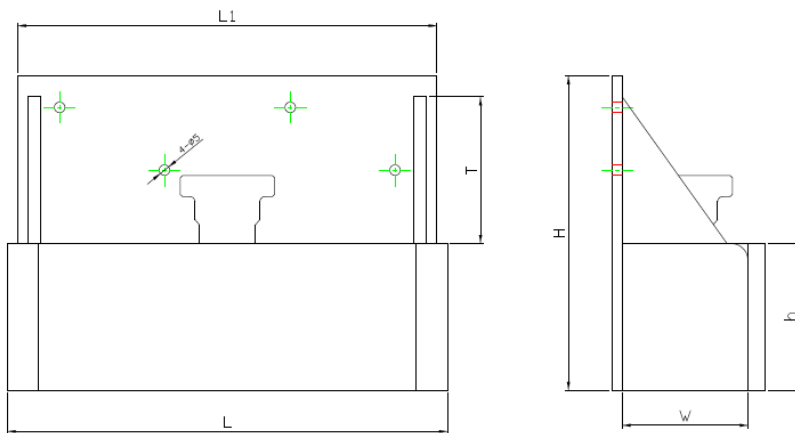

Item No.	L	L1	T	H	h	W	Force			Weight
	mm	mm	mm	mm	mm	mm	Kg	N	Lbs	KG
SM-900-H	210	200	70	150	70	50	900	8820	1982	5.1



*We test the holding force of magnetic assembly by attaching it on a 20mm thick steel sheet at room temperature and then pulling it slowly in vertical direction with the device that is sensitive enough to record the strength at the moment when magnetic assembly is separated from the steel sheet. This is to give you a reference where the actual holding force in real application could be different with the change of, for example, pulling direction, thickness of the surface etc.

Magnet plate

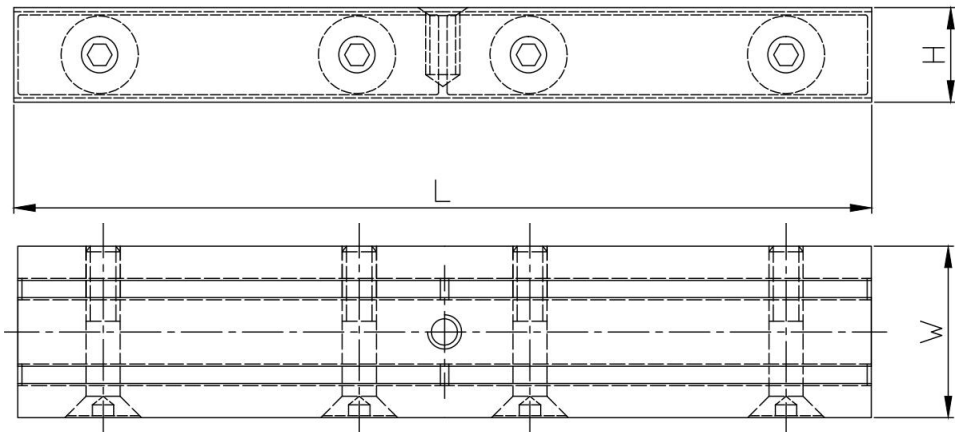

Item No.	L	W	H	Force		
	mm	mm	mm	Kg	N	Lbs
SWNL100F	100	40	22	450	4410	991
SWNL200F-1	200	40	22	900	8820	1982
SWNL200F-2	200	90	22	1500	14700	3304
SWNL240F-1	240	90	22	1800	17640	3965
SWNL240F-2	240	90	22	2100	20580	4625



*We test the holding force of magnetic assembly by attaching it on a 20mm thick steel sheet at room temperature and then pulling it slowly in vertical direction with the device that is sensitive enough to record the strength at the moment when magnetic assembly is separated from the steel sheet. This is to give you a reference where the actual holding force in real application could be different with the change of, for example, pulling direction, thickness of the surface etc.

U profile shutter magnet

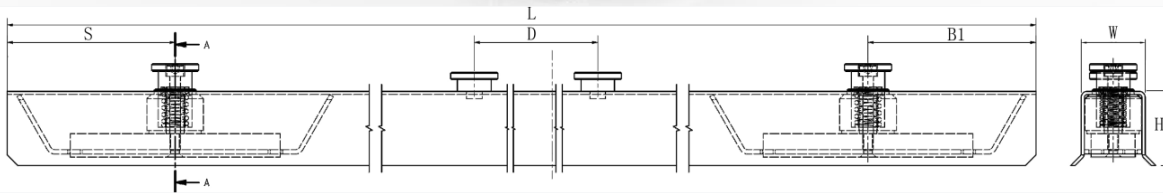
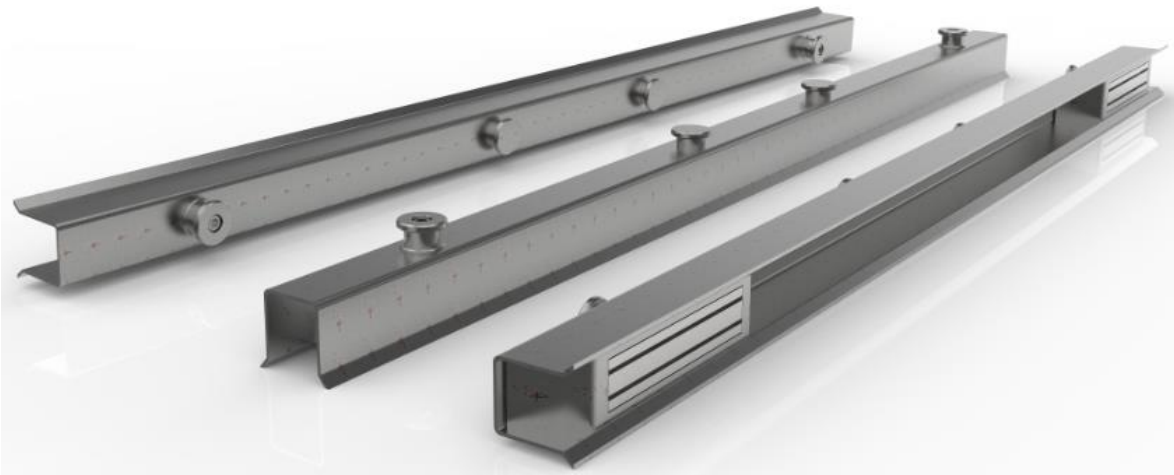

Item No.	L	W	H	S	D	B1
	mm	mm	mm	mm	mm	mm
SM-70/840	840	61	70	160	320	160
SM-70/1000	1000	61	70	160	320	160
SM-70/1200	1200	61	70	160	320	160
SM-70/1400	1400	61	70	160	320	160
SM-70/1500	1500	61	70	160	320	160
SM-70/1560	1560	61	70	160	320	160
SM-70/1800	1800	61	70	160	320	160
SM-70/2100	2100	61	70	160	320	160

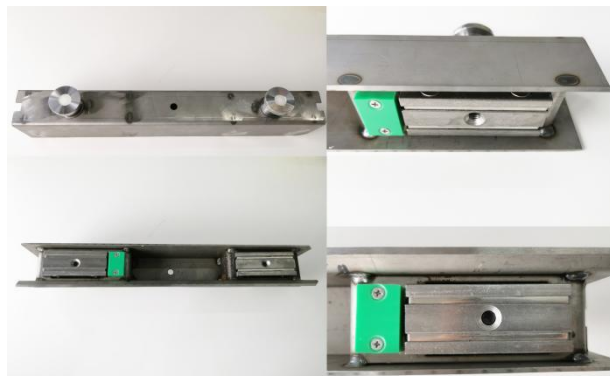

Magnetic recess former

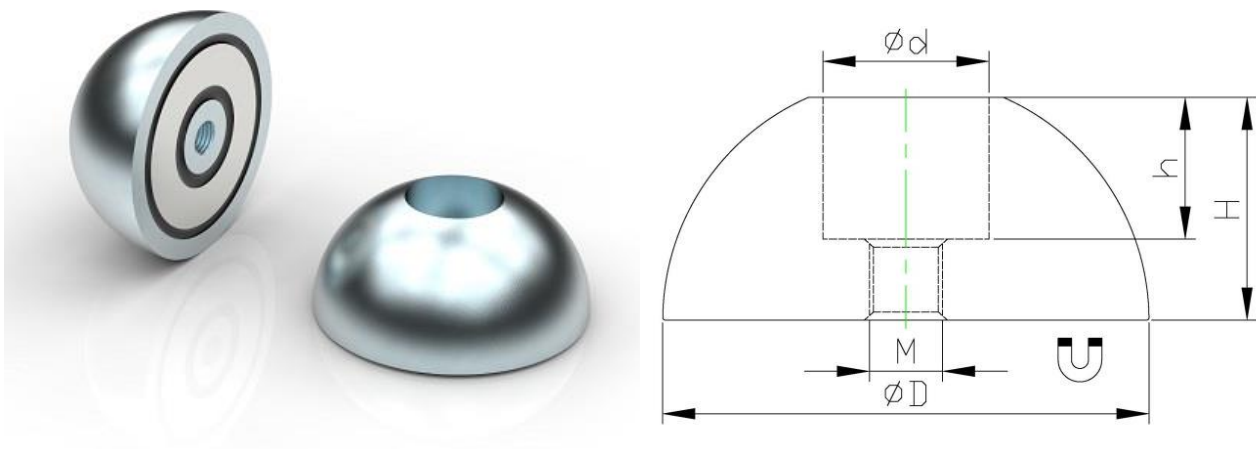

Item No	D	H	h	d	M	Force			Weight
	mm	mm	mm	mm		Lbs	Kg	N	g
RDNB60F-1.3t	60	27.5	17.5	20.5	M8	110	50	490	381.5
RDNB74F-2.5t	74	33	20	30	M10	220	100	980	690
RDNB94F-5t	94	42	27	38	M12	264	120	1176	1400
RDNB118F-10t	118	53	40	48.5	M12	418	190	1862	2625



*We test the holding force of magnetic assembly by attaching it on a 20mm thick steel sheet at room temperature and then pulling it slowly in vertical direction with the device that is sensitive enough to record the strength at the moment when magnetic assembly is separated from the steel sheet. This is to give you a reference where the actual holding force in real application could be different with the change of, for example, pulling direction, thickness of the surface et

Rubberized magnetic former

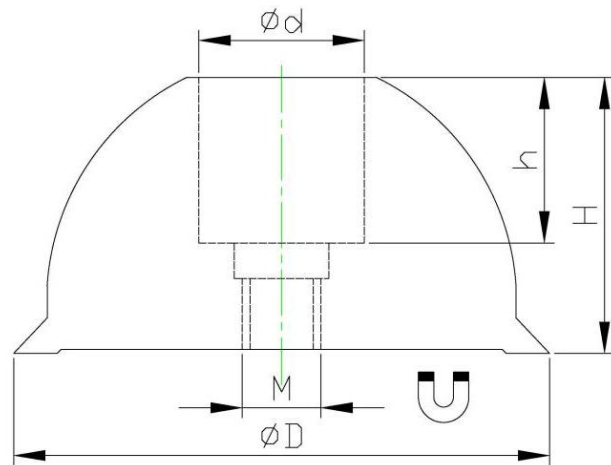

Item No	D	H	h	d	M	Force		
	mm	mm	mm	mm		Lbs	Kg	N
RCNB68F-1.3t	68	35	21	20	M10	110	50	490
RCNB83F-2.5t	83	36	22.5	29	M10	330	150	1470
RCNB105F-5t	105	42	28	38	M12	661	300	2940
RCNB130F-10t	130	53	39	48.5	M12	881	400	3920



*We test the holding force of magnetic assembly by attaching it on a 20mm thick steel sheet at room temperature and then pulling it slowly in vertical direction with the device that is sensitive enough to record the strength at the moment when magnetic assembly is separated from the steel sheet. This is to give you a reference where the actual holding force in real application could be different with the change of, for example, pulling direction, thickness of the surface et

Rubber ring for recess former

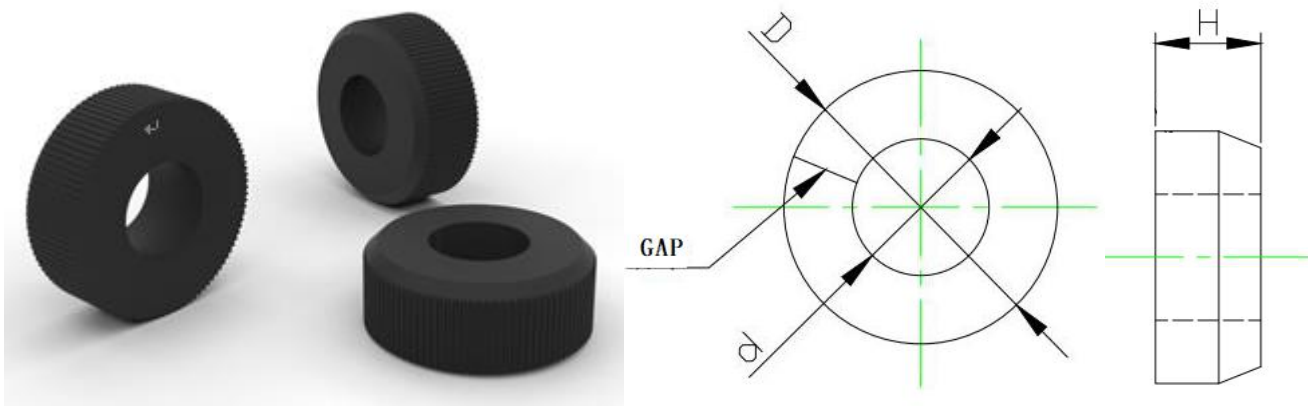

Item No.	D	d	h	For recess former
	mm	mm	mm	mm
PR 1.3t	22	10	11	D60
PR 2.5t	30	15	12.5	D74
PR 5t	39	20	14	D94
PR 10t	49	28	20	D118



Magnetic ferrule

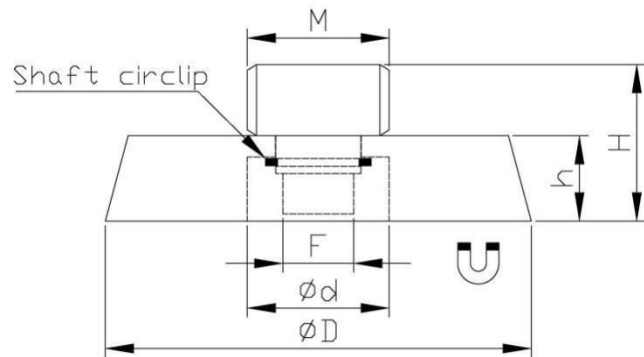

Item No	D	H	h	d	F	M	Force			Weight
	mm	mm	mm	mm			Lbs	Kg	N	g
MFP12	60	22	12	20	10X10	M12	110	50	490	234.1
MFP14	60	22	12	20	10X10	M14	110	50	490	235.5
MFP16	60	22	12	20	10X10	M16	110	50	490	237.9
MFP20	60	22	12	20	10X10	M20	110	50	490	247.1
MFP24	74	22	12	20	10X10	M24	220	100	980	381.2
MFP30	90	24	12	20	10X10	M30	264	120	1176	580.5
MFP36	90	24	12	20	10X10	M36	264	120	1176	610.2
MFP42	115	30	15	20	10X10	M42	405	180	1764	1222
MFP52	135	30	15	20	10X10	M52	405	180	1764	1742



*We test the holding force of magnetic assembly by attaching it on a 20mm thick steel sheet at room temperature and then pulling it slowly in vertical direction with the device that is sensitive enough to record the strength at the moment when magnetic assembly is separated from the steel sheet. This is to give you a reference where the actual holding force in real application could be different with the change of, for example, pulling direction, thickness of the surface etc.

Precast insert magnet

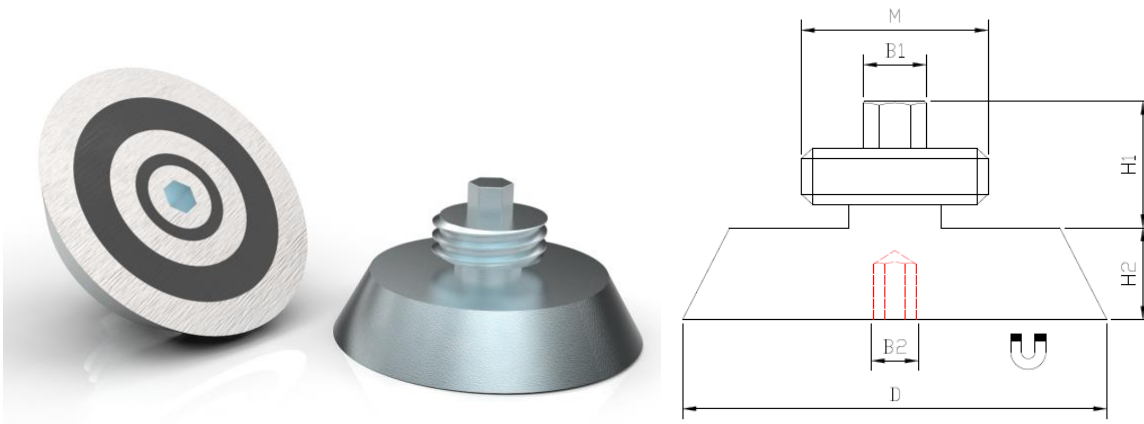

Item No	D	H1	H2	B1	B2	M	Force			Weight
	mm	mm	mm	mm	mm		Lbs	Kg	N	g
RBNB42x11.7mm	42	16.1	11.7	8	6	M16	110	50	490	95
RBNB55x11.7mm	55	16.1	11.7	8	6	M24	220	100	980	178

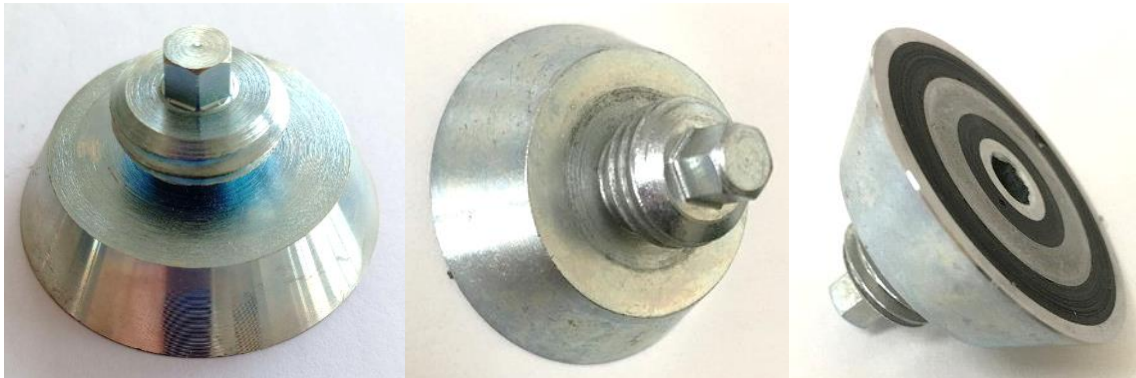

*We test the holding force of magnetic assembly by attaching it on a 20mm thick steel sheet at room temperature and then pulling it slowly in vertical direction with the device that is sensitive enough to record the strength at the moment when magnetic assembly is separated from the steel sheet. This is to give you a reference where the actual holding force in real application could be different with the change of, for example, pulling direction, thickness of the surface etc.

Magnetic nailing plate

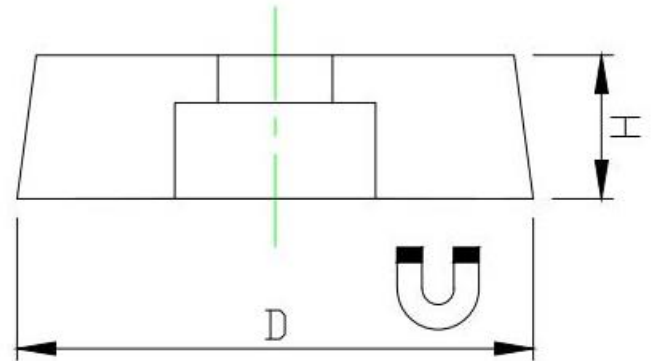
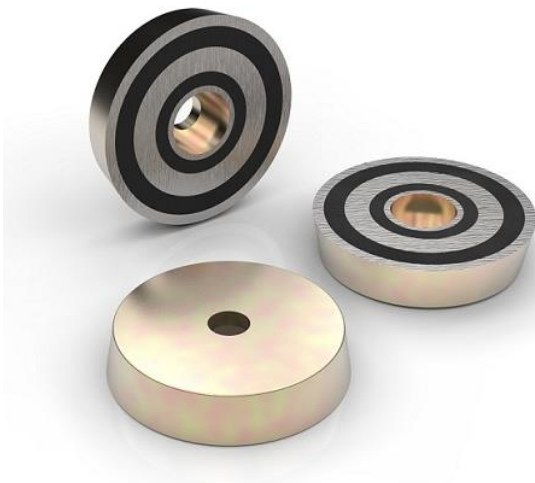

Item No.	D	H	Force			Weight
	mm	mm	Kg	N	Lbs	g
RBNB54x15	54	15	105	1029	231	240
RBNB70x15	70	15	190	1862	418	320



*We test the holding force of magnetic assembly by attaching it on a 20mm thick steel sheet at room temperature and then pulling it slowly in vertical direction with the device that is sensitive enough to record the strength at the moment when magnetic assembly is separated from the steel sheet. This is to give you a reference where the actual holding force in real application could be different with the change of, for example, pulling direction, thickness of the surface etc.

Precast electrical box magnet

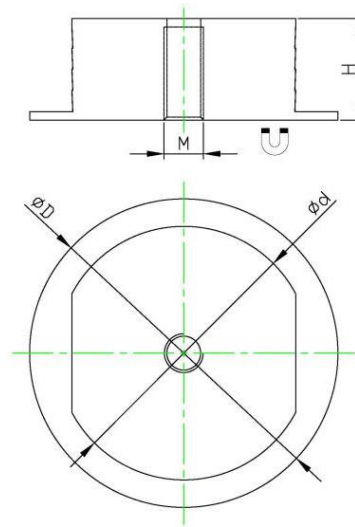

Item No	D	d	H	M	Force			Weight
	mm	mm	mm		Lbs	Kg	N	g
RONB73F	73	60	24	8	132	60	588	296.7



*We test the holding force of magnetic assembly by attaching it on a 20mm thick steel sheet at room temperature and then pulling it slowly in vertical direction with the device that is sensitive enough to record the strength at the moment when magnetic assembly is separated from the steel sheet. This is to give you a reference where the actual holding force in real application could be different with the change of, for example, pulling direction, thickness of the surface etc.

Precast magnet holder plate

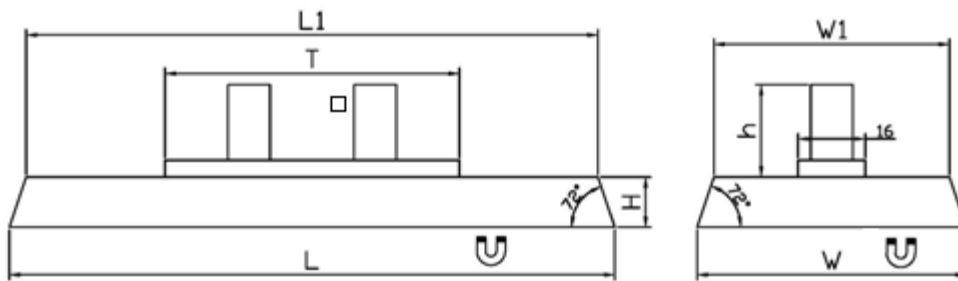
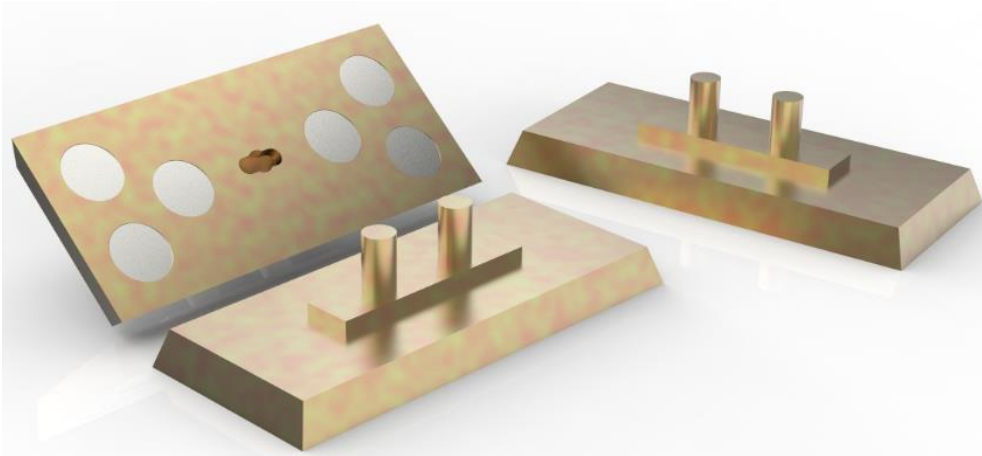

Item No.	L	L1	W	W1	H	T	h	Force		
	mm	mm	mm	mm	mm	mm	mm	Kg	N	Lbs
8NGXXF0144	144	136	64	56	12	70	22	90	882	198

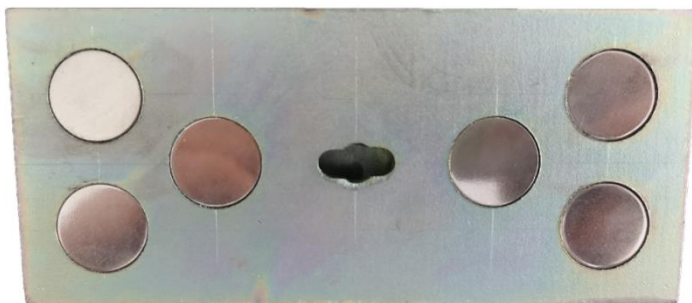

*We test the holding force of magnetic assembly by attaching it on a 20mm thick steel sheet at room temperature and then pulling it slowly in vertical direction with the device that is sensitive enough to record the strength at the moment when magnetic assembly is separated from the steel sheet. This is to give you a reference where the actual holding force in real application could be different with the change of, for example, pulling direction, thickness of the surface etc.

Precast wire loop box magnet

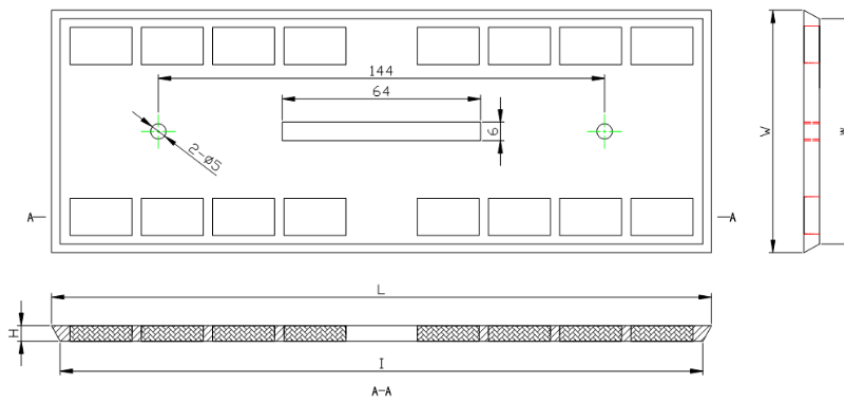
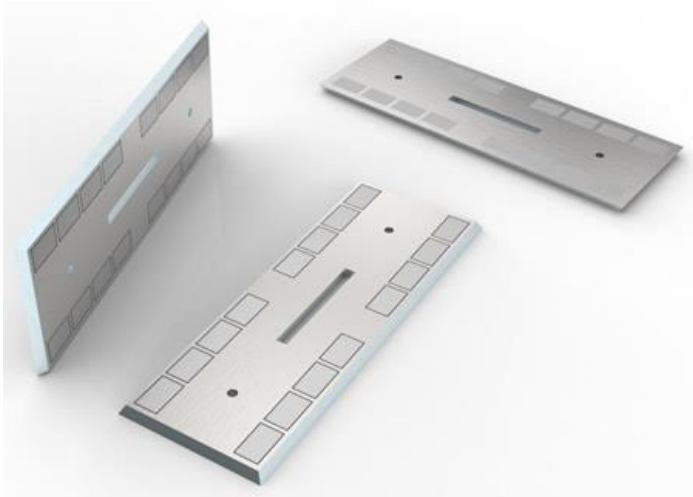

Item No.	L	I	W	w	H	QTY OF MAGNETS
	mm	mm	mm	mm	mm	PCS
NMP-213	213	207.5	78	72.5	5	16
NMP-178	178	172.5	78	72.5	5	12

