

01 Rubber coated magnet

Rubber coated magnets are widely used for wind power and many other industries.

By using magnetic products, you will have easy access to great flexibility and high efficiency. No welding, no drilling, easy operation. You can easily mount it or remove it quickly without damaging the construction.



The advantages of our rubber coated magnets

- 1) Our rubber coated magnetic parts are specially designed according to practical requirement in the specified industry.
- 2) The rubber material we use features good chemical stability in harsh environment. The rubber also protects holding surface from scratch.
- 3) We are happy to develop products according to your specific application requirements.

NdFeB rubber coated magnet with female thread

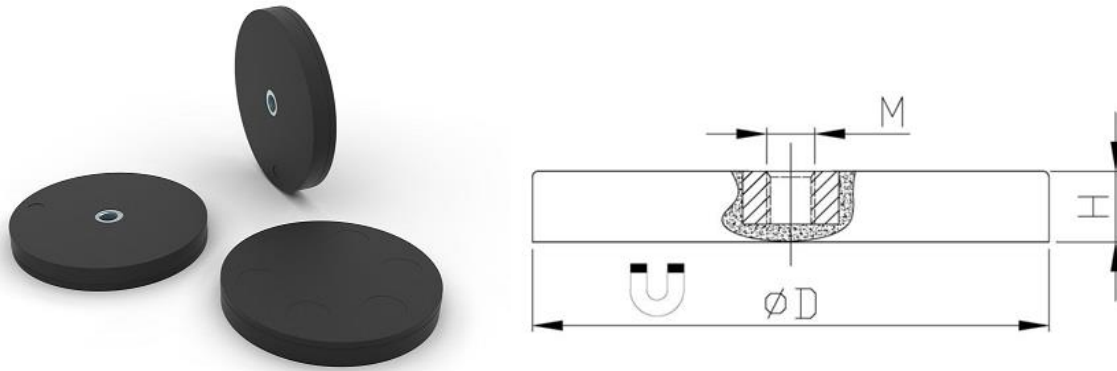

Item No.	D	H	M	Force			Weight
	mm	mm		Kg	N	Lbs	g
RCND22F	22	6	M4	5.9	58	13	10
RCND31F	31	6	M5	9	89	20	21
RCND43F	43	6	M6	10	100	22	36
RCND66F	66	8.5	M6	25	250	56	107
RCND88F	88	8.5	M6	56	550	123	210



* We test the holding force of magnetic assembly by attaching it on a 20mm thick steel sheet at room temperature and then pulling it slowly in vertical direction with the device that is sensitive enough to record the strength at the moment when magnetic assembly is separated from the steel sheet. This is to give you a reference where the actual holding force in real application could be different with the change of, for example, pulling direction, thickness of the surface etc.

NdFeB rubber coated magnet with screw bush

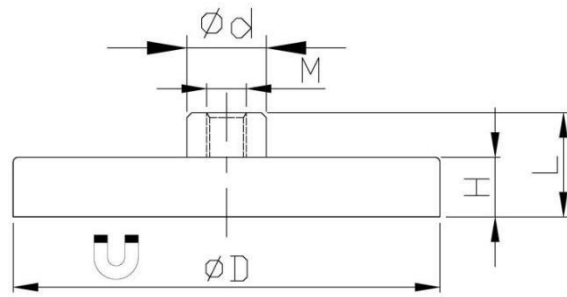
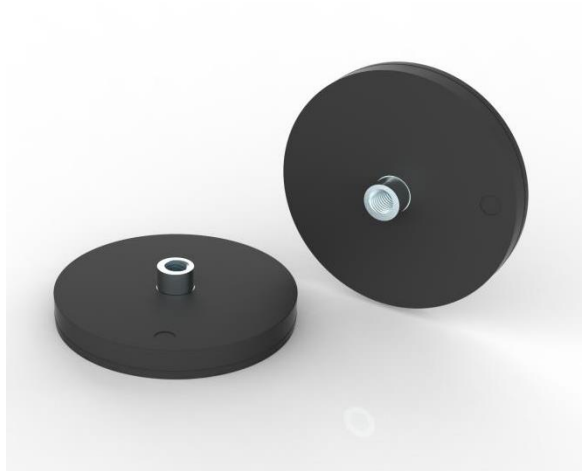

Item No.	D	d	H	L	M	Force		
	mm	mm	mm	mm		Kg	N	Lbs
RCND22F-11.5	22	8	6	11.5	M4	5.9	58	13
RCND31F-11.5	31	8	6	11.5	M4	9	89	20
RCND43F-10.5	43	8	6	10.5	M4	10	100	22
RCND66F-15	66	10	8.5	15	M5	25	250	56
RCND88F-17	88	12	8.5	17	M8	56	550	123



* We test the holding force of magnetic assembly by attaching it on a 20mm thick steel sheet at room temperature and then pulling it slowly in vertical direction with the device that is sensitive enough to record the strength at the moment when magnetic assembly is separated from the steel sheet. This is to give you a reference where the actual holding force in real application could be different with the change of, for example, pulling direction, thickness of the surface etc.

NdFeB rubber coated magnet with threaded stud

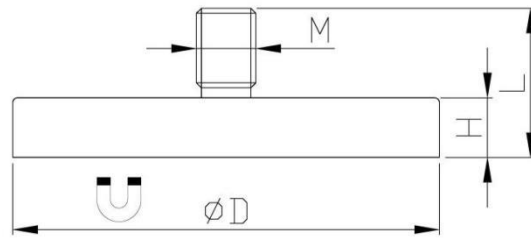

Item No.	D	H	L	M	Force			Weight
	mm	mm	mm		Kg	N	Lbs	g
RCND12M	12	7	15.5	M4	1.3	13	2.9	4.5
RCND22M	22	6	12.5	M4	5.9	58	13	10
RCND31M	31	6	18	M5	9	89	20	21
RCND43M	43	6	21	M6	10	100	22	36
RCND50M	50	10.5	30.5	M6	46	450	101	42.5
RCND64M	64	11.5	31.5	M8	91	900	202	208.2
RCND66M	66	8.5	23.5	M6	25	250	56	107
RCND88M	88	8.5	23.5	M8	56	550	123	210



* We test the holding force of magnetic assembly by attaching it on a 20mm thick steel sheet at room temperature and then pulling it slowly in vertical direction with the device that is sensitive enough to record the strength at the moment when magnetic assembly is separated from the steel sheet. This is to give you a reference where the actual holding force in real application could be different with the change of, for example, pulling direction, thickness of the surface etc.

NdFeB rubber coated magnet with cylinder bore

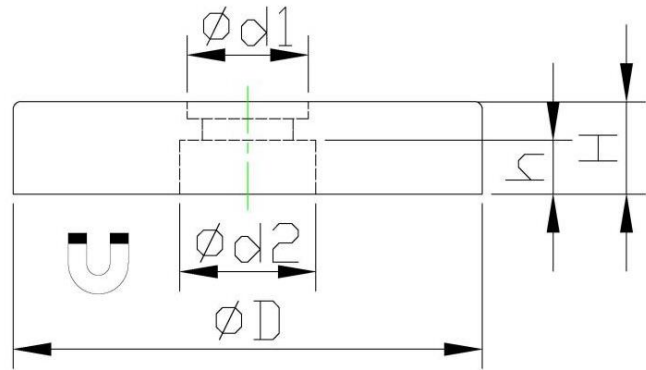
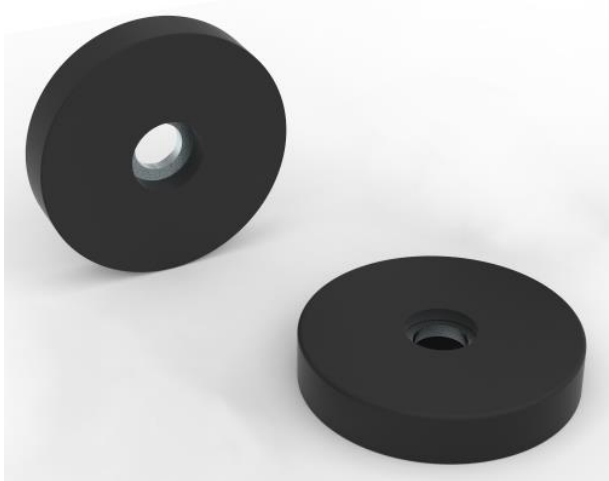

Item No.	D	H	h	d1	d2	Force			Weight
	mm	mm	mm	mm	mm	Kg	N	Lbs	g
RCND22B	22	6	3.5	4	8.2	3.8	38	8.54	8
RCND31B	31	6	3.5	6	9	9	89	20	20



* We test the holding force of magnetic assembly by attaching it on a 20mm thick steel sheet at room temperature and then pulling it slowly in vertical direction with the device that is sensitive enough to record the strength at the moment when magnetic assembly is separated from the steel sheet. This is to give you a reference where the actual holding force in real application could be different with the change of, for example, pulling direction, thickness of the surface etc.

NdFeB rubber coated magnet with screw hole

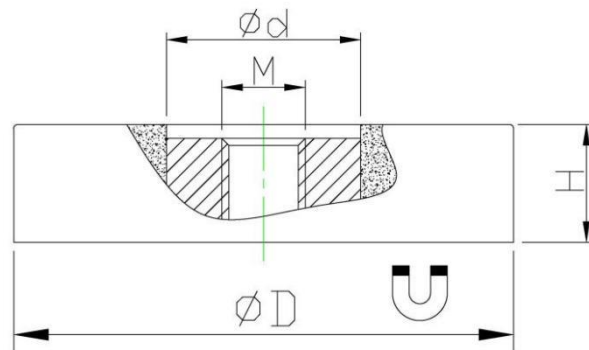
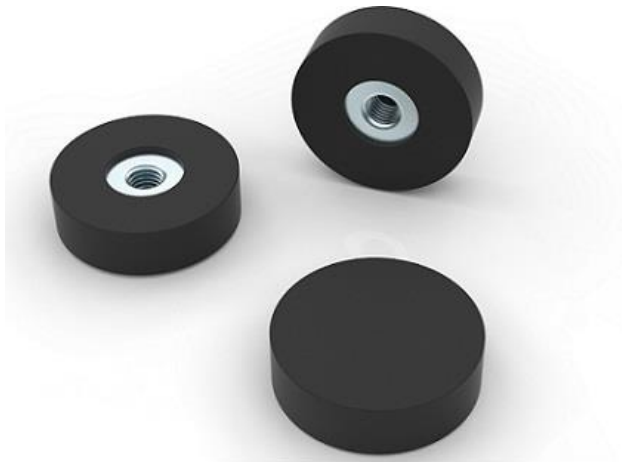

Item No.	D	H	d	M	Force			Weight
	mm	mm	mm		Kg	N	Lbs	g
RCND20F	20	6	8	M4	3	31	7	7.5
RCND29F	29	8.5	12	M5	11	108	22	28
RCND36F	36	8.5	14	M6	20	201	45	49
RCND45F	45	9.5	14	M6	30	301	67	80

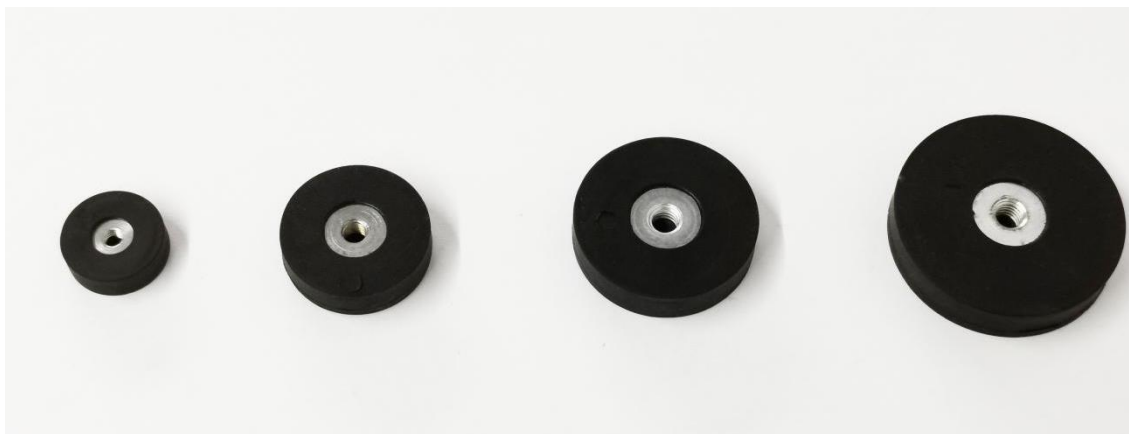

* We test the holding force of magnetic assembly by attaching it on a 20mm thick steel sheet at room temperature and then pulling it slowly in vertical direction with the device that is sensitive enough to record the strength at the moment when magnetic assembly is separated from the steel sheet. This is to give you a reference where the actual holding force in real application could be different with the change of, for example, pulling direction, thickness of the surface etc.

NdFeB rubber coated magnet with mounting hole

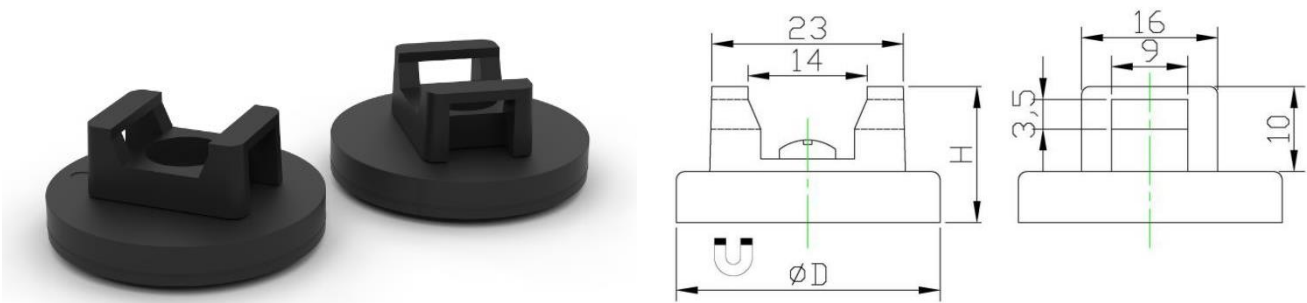

Item No.	D	H	Force			Weight
	mm	mm	Kg	N	Lbs	g
RCND22H	22	16	5.9	58	13	11.5
RCND31H	31	16	9	89	20	22.5
RCND43H	43	16	10	100	22	37.5



* We test the holding force of magnetic assembly by attaching it on a 20mm thick steel sheet at room temperature and then pulling it slowly in vertical direction with the device that is sensitive enough to record the strength at the moment when magnetic assembly is separated from the steel sheet. This is to give you a reference where the actual holding force in real application could be different with the change of, for example, pulling direction, thickness of the surface etc.

Black rubber coated magnet with bore and counterbore

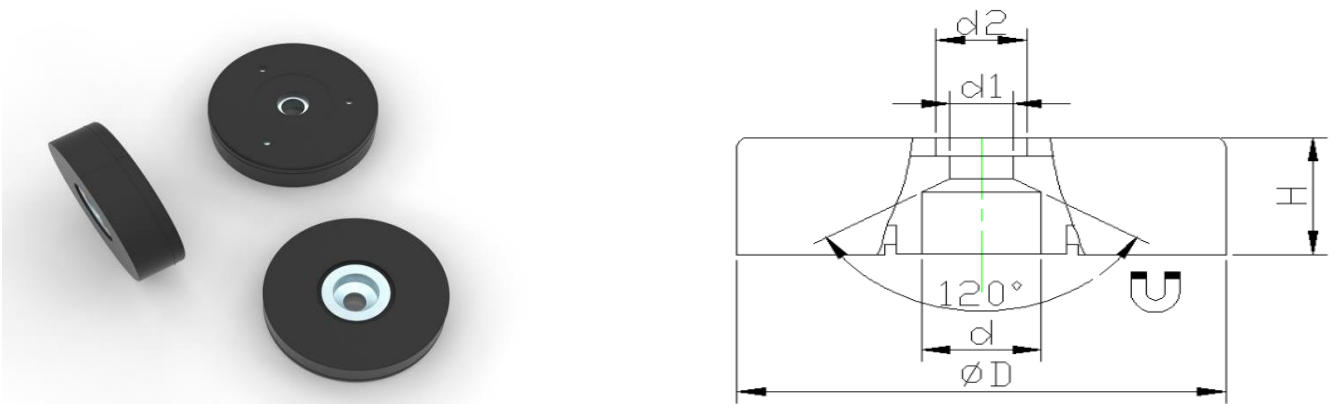

Item No.	D	H	d	d1	d2	Force			Magnet	Weight
	mm	mm	mm	mm	mm	Kg	N	Lbs		g
RCFB43C-B	43	12.5	10.5	5.5	8	8	80	18	Ferrite	76
RCNB43C-B	43	12.5	10.5	5.5	8	26	260	58	NdFeB	86



* We test the holding force of magnetic assembly by attaching it on a 20mm thick steel sheet at room temperature and then pulling it slowly in vertical direction with the device that is sensitive enough to record the strength at the moment when magnetic assembly is separated from the steel sheet. This is to give you a reference where the actual holding force in real application could be different with the change of, for example, pulling direction, thickness of the surface etc.

Rectangular NdFeB Rubber coated magnet with female thread

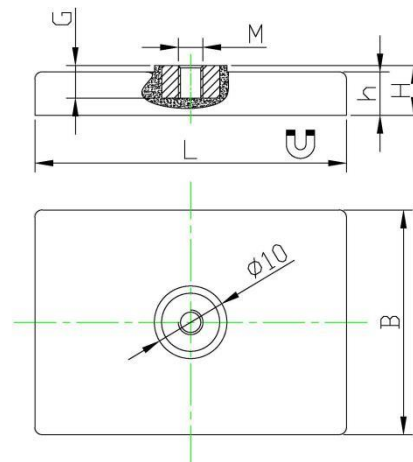
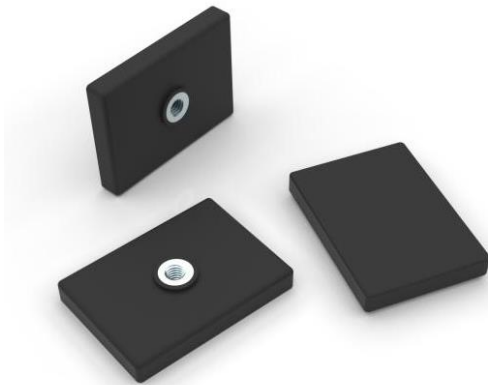
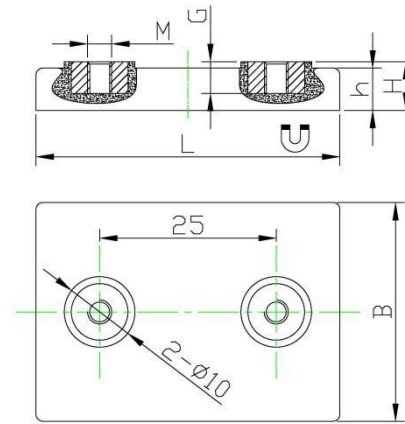

Item No.	L	B	H	h	MxG	Force			Weight
	mm	mm	mm	mm	mm	Kg	N	Lbs	g
RCNL43F-2M4	43	31	6.9	6	M4x4.5	13	130	28	28.5
RCNL43F-M4	43	31	6.9	6	M4x4.5	13	130	28	27.5



* We test the holding force of magnetic assembly by attaching it on a 20mm thick steel sheet at room temperature and then pulling it slowly in vertical direction with the device that is sensitive enough to record the strength at the moment when magnetic assembly is separated from the steel sheet. This is to give you a reference where the actual holding force in real application could be different with the change of, for example, pulling direction, thickness of the surface etc.

Rectangular NdFeB rubber coated magnet with threaded stud

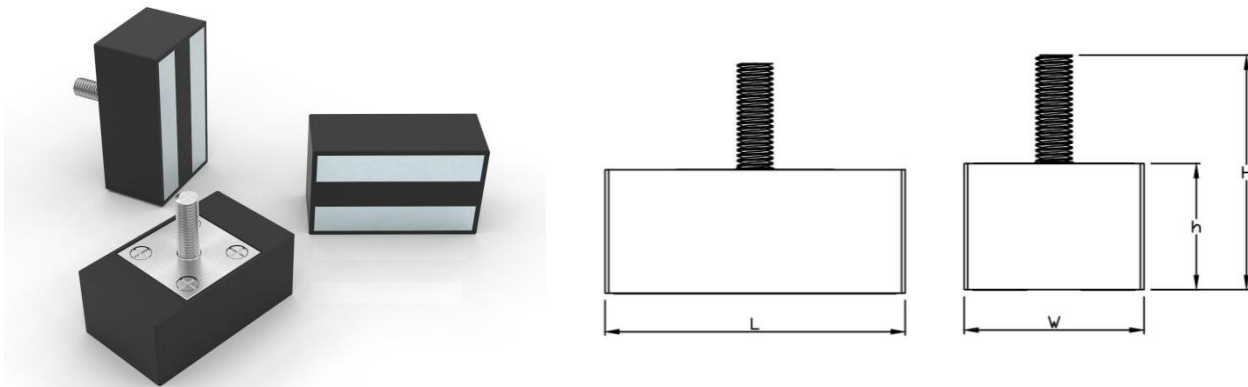

Item No.	L	W	h	H	M	Force			Weight
	mm	mm	mm	mm		Kg	N	Lbs	g
RCNL84M-1200	85	50	35	65	10	122	1200	270	975
RCNL84M-3500	85	50	35	65	10	356	3500	786	975



* We test the holding force of magnetic assembly by attaching it on a 20mm thick steel sheet at room temperature and then pulling it slowly in vertical direction with the device that is sensitive enough to record the strength at the moment when magnetic assembly is separated from the steel sheet. This is to give you a reference where the actual holding force in real application could be different with the change of, for example, pulling direction, thickness of the surface etc.

01 Rubber Coated Magnet

Rectangular NdFeB rubber coated magnet with flange screws

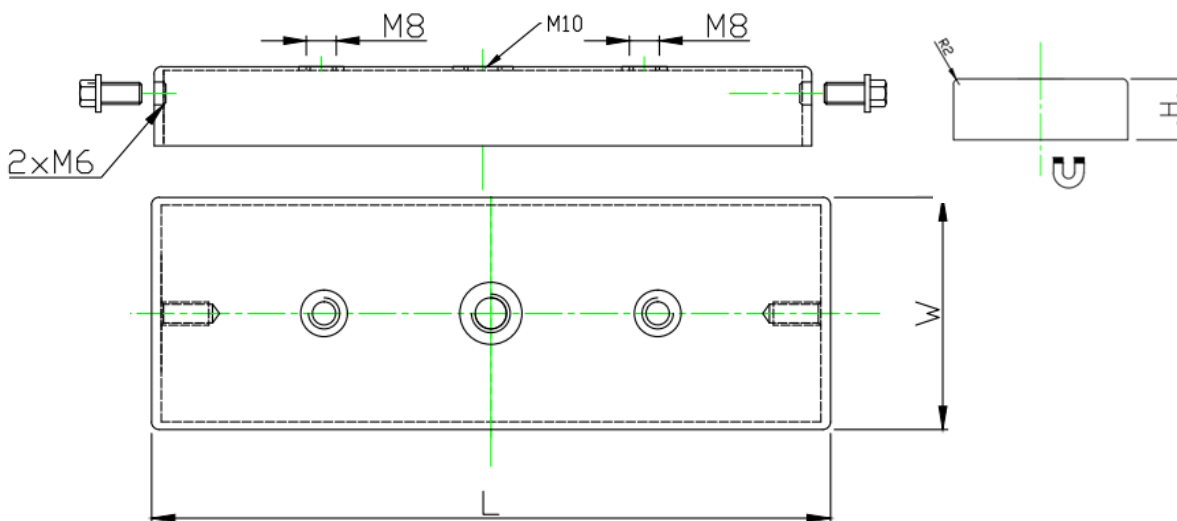
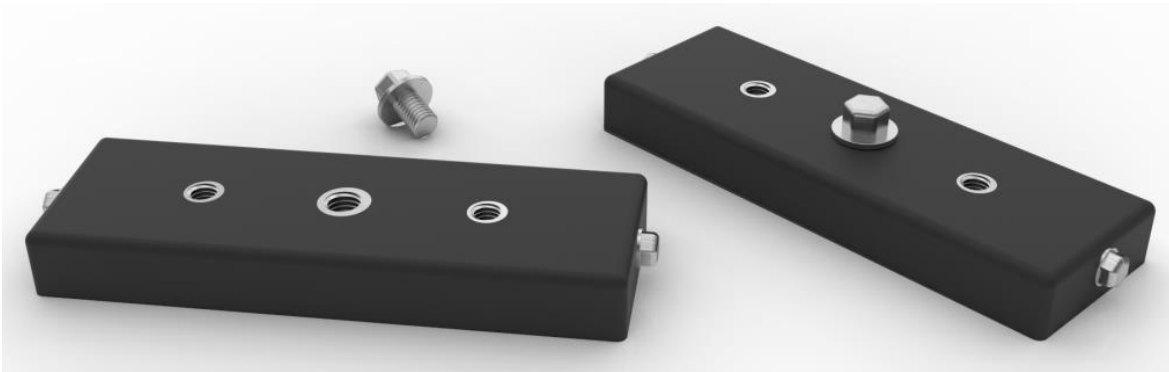

Item No.	L	W	H	Force		Weight	
	mm	mm	mm	Kg	N	Lbs	g
RCHNL7F-N	175	59	20	340	3334	749	1630



* We test the holding force of magnetic assembly by attaching it on a 20mm thick steel sheet at room temperature and then pulling it slowly in vertical direction with the device that is sensitive enough to record the strength at the moment when magnetic assembly is separated from the steel sheet. This is to give you a reference where the actual holding force in real application could be different with the change of, for example, pulling direction, thickness of the surface etc.

Rectangular NdFeB rubber coated magnet with male thread

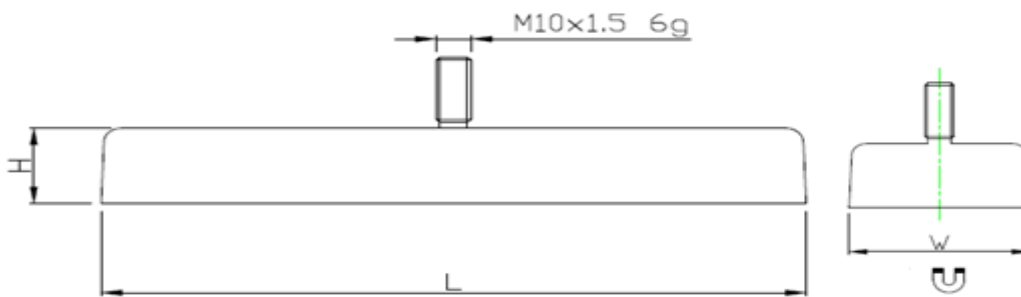
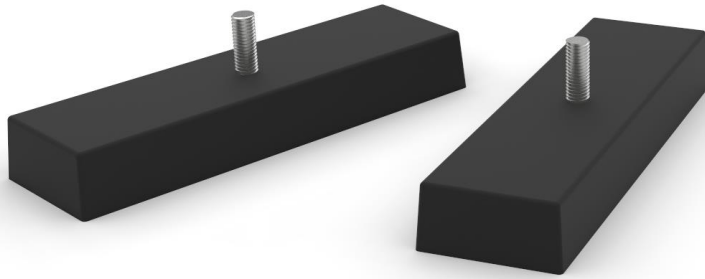

Item No.	L	W	H	Force			Weight
	mm	mm	mm	Kg	N	Lbs	g
RCHNL8M	203	61	27.5	304	2979	670	2050



* We test the holding force of magnetic assembly by attaching it on a 20mm thick steel sheet at room temperature and then pulling it slowly in vertical direction with the device that is sensitive enough to record the strength at the moment when magnetic assembly is separated from the steel sheet. This is to give you a reference where the actual holding force in real application could be different with the change of, for example, pulling direction, thickness of the surface etc.

Rectangular NdFeB rubber coated magnet with male thread

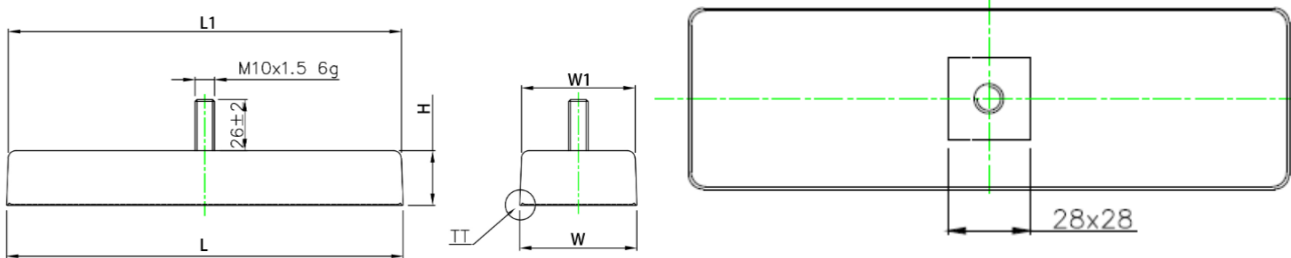
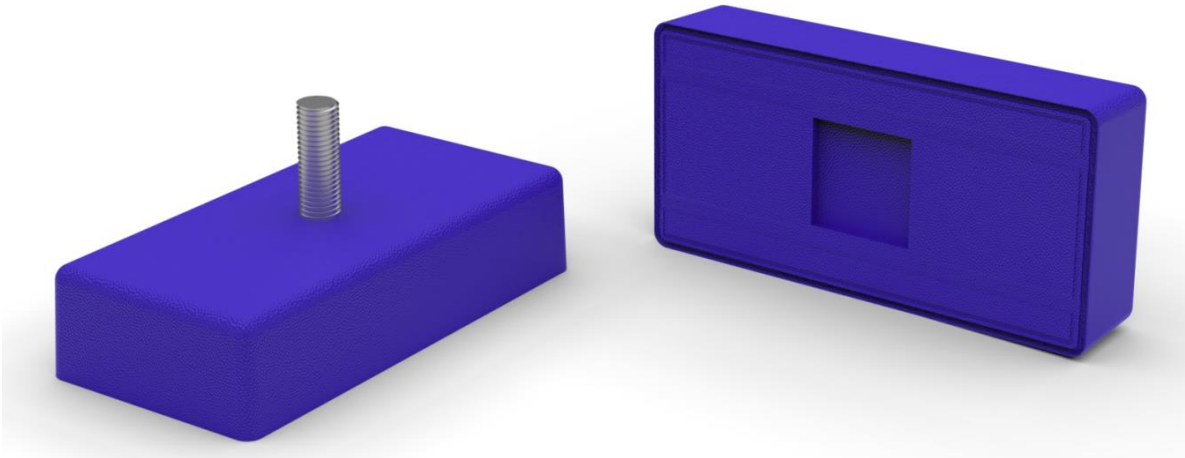

Item No.	L	L1	W	W1	H	M	Force			Weight
	mm	mm	mm	mm	mm		Kg	N	Lbs	g
RCHNL4M-VT	100.5	98.8	61	59.3	28	M10	100	1000	224	900
RCHNL5M-VT	125	123.3	61	59.3	28	M8/M10	200	2000	449	1000
RCHNL8M-VT	203	201	61	59	28	M10	400	4000	899	1693

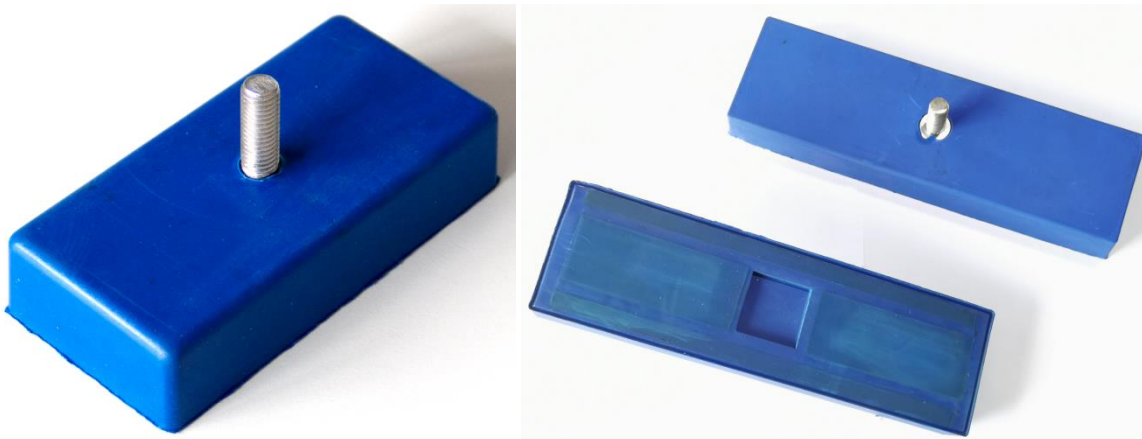

* We test the holding force of magnetic assembly by attaching it on a 20mm thick steel sheet at room temperature and then pulling it slowly in vertical direction with the device that is sensitive enough to record the strength at the moment when magnetic assembly is separated from the steel sheet. This is to give you a reference where the actual holding force in real application could be different with the change of, for example, pulling direction, thickness of the surface etc.

Oval shape NdFeB rubber coated magnet

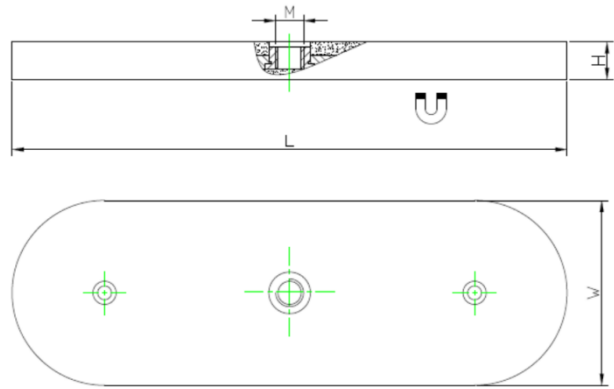
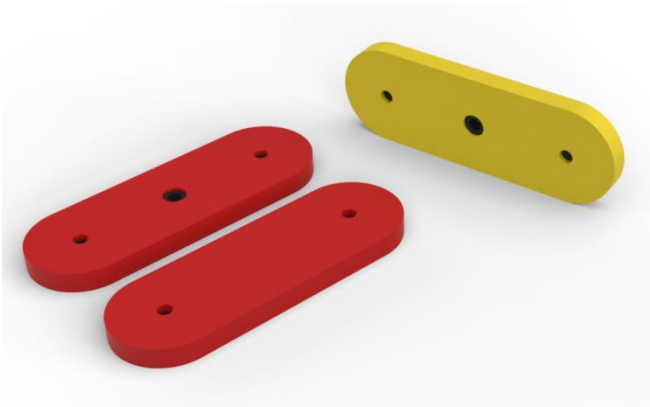

Item No.	L	W	H	M	Force			Weight
	mm	mm	mm		Kg	N	Lbs	g
RCNL120-R	120	40	8.1	M6	38	372	83	142
RCNL120-Y	120	40	8.1	M6	38	372	83	142

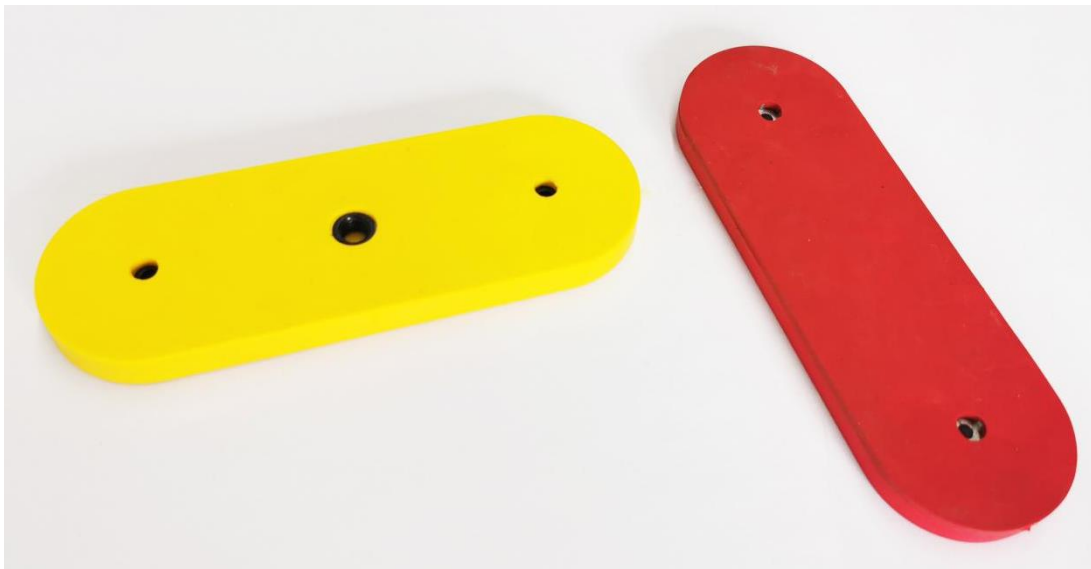

* We test the holding force of magnetic assembly by attaching it on a 20mm thick steel sheet at room temperature and then pulling it slowly in vertical direction with the device that is sensitive enough to record the strength at the moment when magnetic assembly is separated from the steel sheet. This is to give you a reference where the actual holding force in real application could be different with the change of, for example, pulling direction, thickness of the surface etc.

NdFeB rubber coated magnet with J hook, rectangular

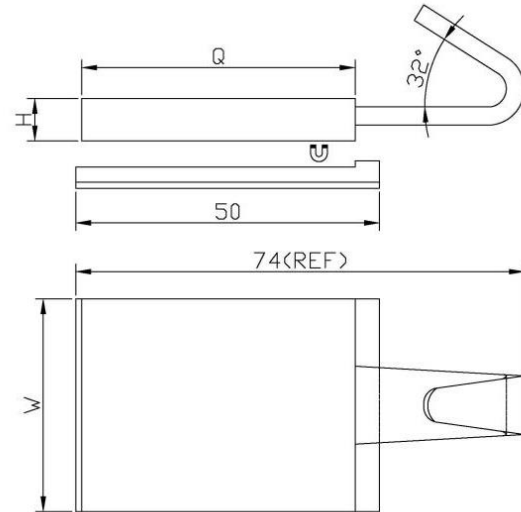
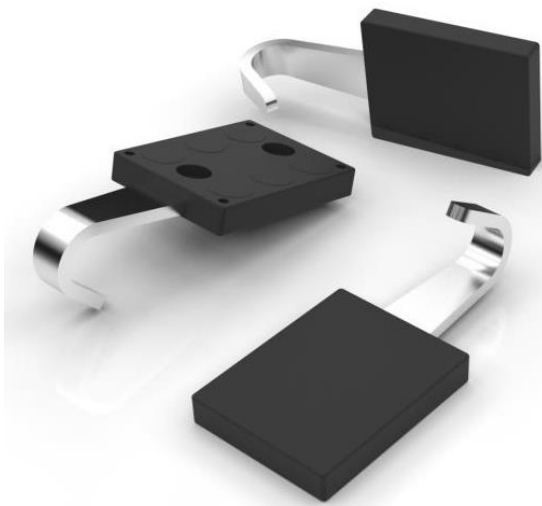

Item No.	L	W	Q	H	Force			Weight
	mm	mm	mm	mm	Kg	N	Lbs	g
RCNL74L	74	35	45	7	10	98	22	53.7



* We test the holding force of magnetic assembly by attaching it on a 20mm thick steel sheet at room temperature and then pulling it slowly in vertical direction with the device that is sensitive enough to record the strength at the moment when magnetic assembly is separated from the steel sheet. This is to give you a reference where the actual holding force in real application could be different with the change of, for example, pulling direction, thickness of the surface etc.

Customized rubber coated magnet



* We test the holding force of magnetic assembly by attaching it on a 20mm thick steel sheet at room temperature and then pulling it slowly in vertical direction with the device that is sensitive enough to record the strength at the moment when magnetic assembly is separated from the steel sheet. This is to give you a reference where the actual holding force in real application could be different with the change of, for example, pulling direction, thickness of the surface etc.

01 Rubber Coated Magnet